

# Rod Ends Series K - Steel on Steel

## Series GAO

Rod Ends with male thread made from free-cutting or heat-treated steel, zinc plated without the insert, running surface steel on steel

High axial load in one direction only. To be used only with limited oscillating movements

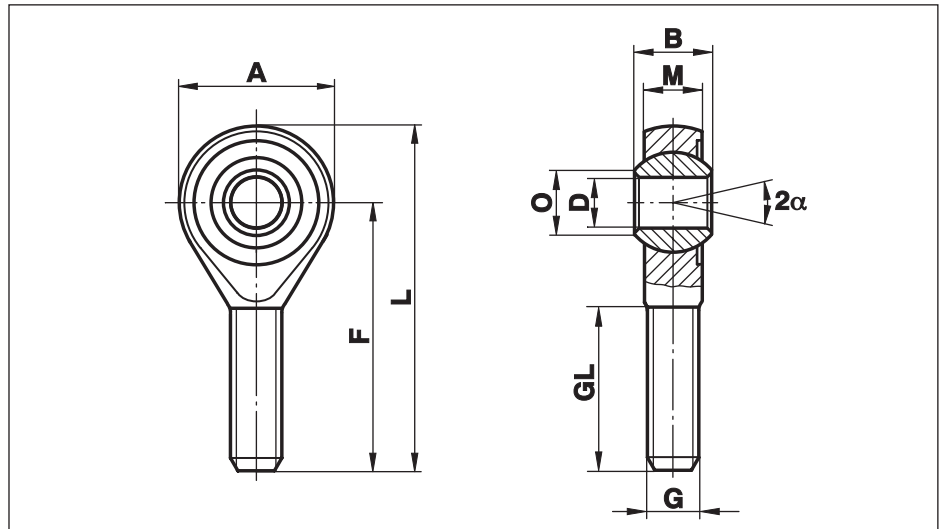

Size (D)	B	M	A	F	L	O	G	GL	Static load C <sub>0</sub> kN	Dynamic load C kN	Limiting speed rev/min	Weight g
5	8	6,00	18	33	42	7,7	M 5	20	4,3	2,2		13
6	9	6,75	20	36	46	8,9	M 6	22	6,0	2,8		20
8	12	9,00	24	42	54	10,4	M 8	25	11,0	4,6	not to be used for complete revolutions	33
10	14	10,50	28	48	62	12,9	M 10	29	17,4	6,5		56
12	16	12,00	32	54	70	15,4	M 12	33	25,5	8,5		87
14	19	13,50	36	60	78	16,8	M 14	38	26,5	11,0		129
16	21	15,00	42	66	87	19,3	M 16	40	36,5	14,0		189
20	25	18,00	50	78	103	24,3	M 20x1,5	47	63,0	20,5	348	

## Materials:

**Housing:** up to size 12 turned, from free-cutting steel to 9SMnPb28K, 12L13  
from size 14 forged, from heat-treated steel to C22, M1023

**Ball:** Bearing steel to 100Cr6, Aisi 52100, hardened, ground, polished

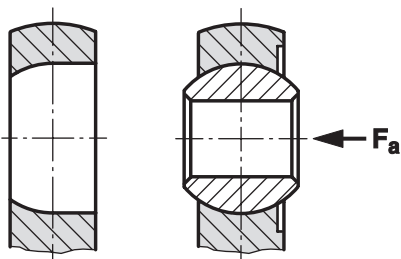

The base in the steel housing is cylindrically turned from one side and, starting from the centre line, it runs to suit the ball's contour (see drawing). Hence a high axial load towards the turned radius is possible.